

CAD FILE:

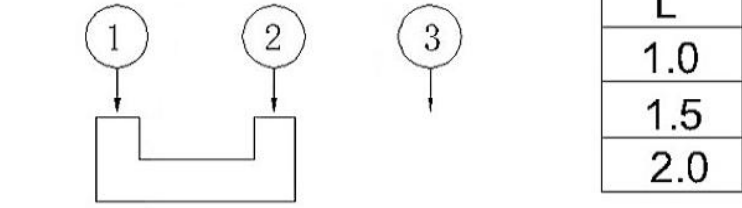

L
1.0
1.5
2.0

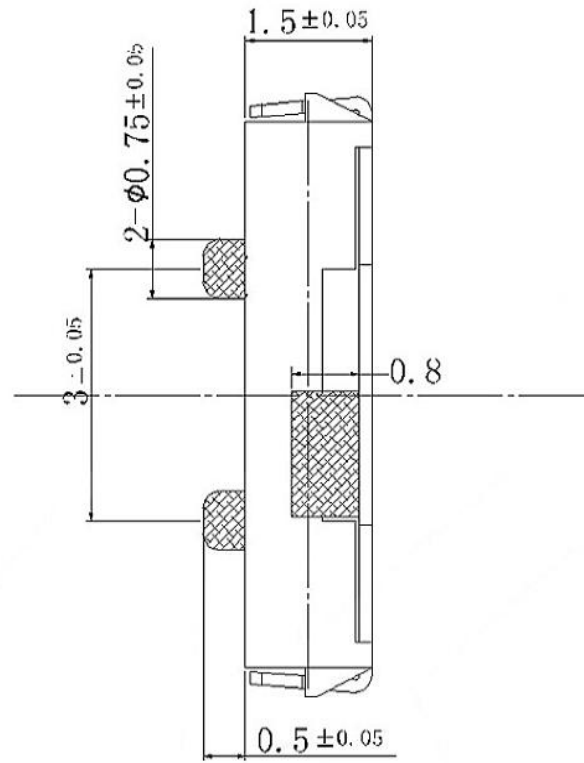
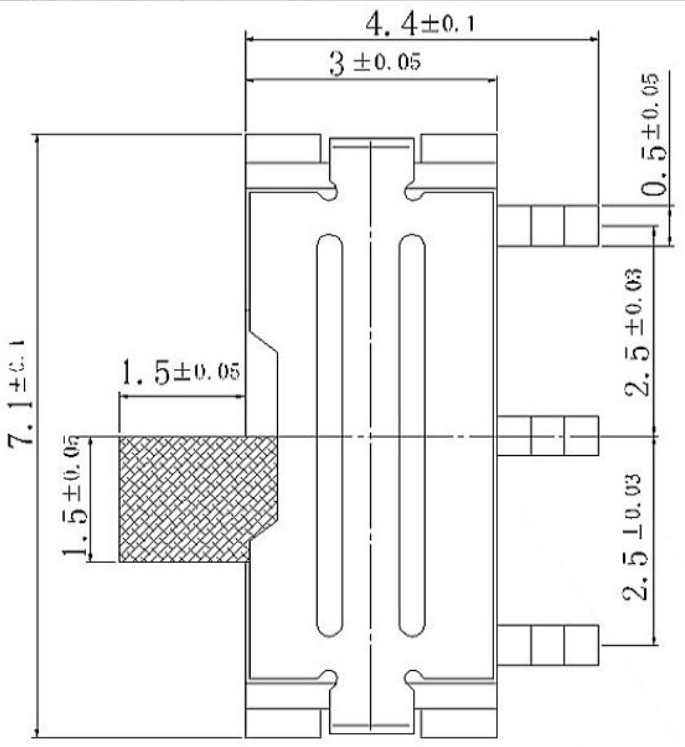
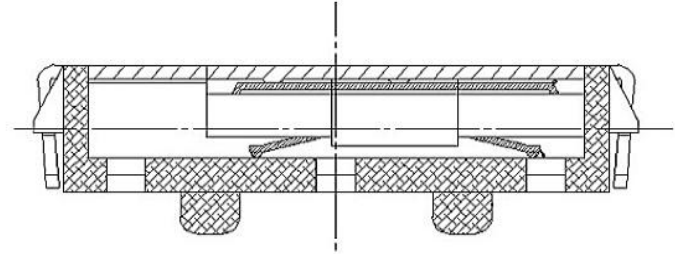

NOTE:  
 Rating: DC 12V 50mA  
 Operating  
 Force: 200±100gf  
 Lifetime: 10,000 Cycles

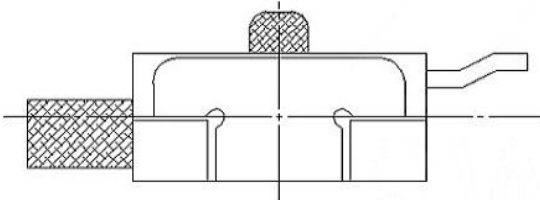
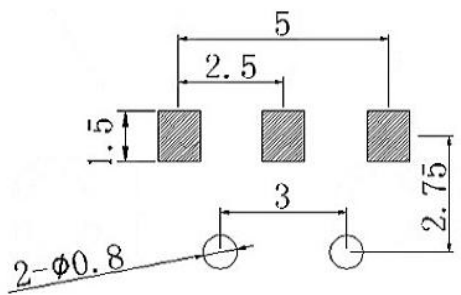

注: "\*"表示关键尺寸(6个)

NO.	PARTS	MATERIALS	Q'TY	FINISH	TOLERANCE				
8					UNLESS SPECIFIED				
7	STEEL BALL	STEEL	1	NATURAL					
6	SPRING	STEEL WIRE	1	NATURAL	WITHIN	A	2012-10-26	初版	
5	CONTACT CLIP	PBS STRIP	2	Ag PLATED	OVER	ISSUE	DATE	DESCRIPTIONS OF REVISION	
4	TERMINAL	BRASS STRIP	8	Ag PLATED	TITLE : SLIDE SWITCH			UNIT : mm	DRWG NO.:
3	BASE	PHENOLIC RESIN	1	NATURAL	MODEL:			SCALE: 3:1	DWN.
2	FRAME	STEEL STRIP	1	Ni PLATED					2012-10-26
1	KNOB	POM	1	BLACK					2012-10-26
								APPD.	

**东莞市高迪电子有限公司**  
 DONGGUAN GAODI ELECTRONICS CO., LTD.